

1-800-639-2199

Fax (603) 224-2927

Headwalls\Standard\Wing Walls\Dual 15 in\_RCP\_Wing Wall (v)

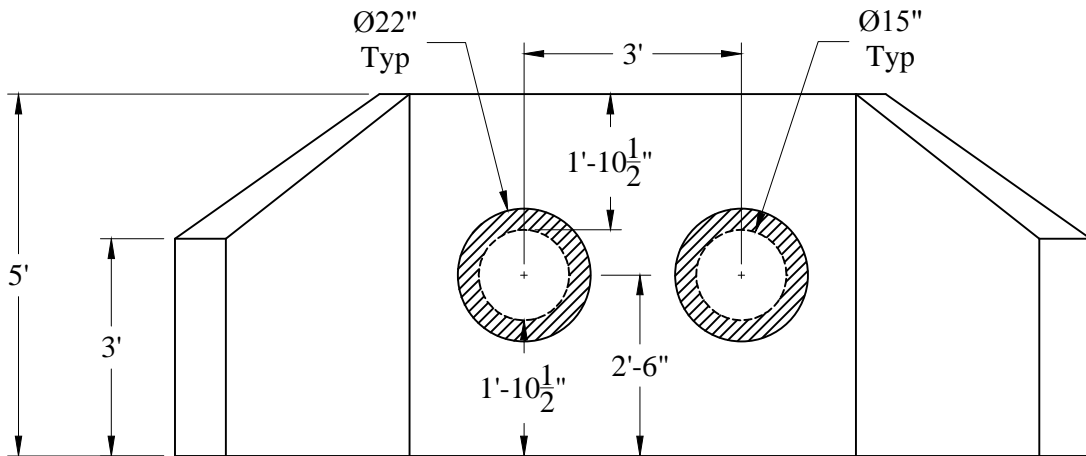
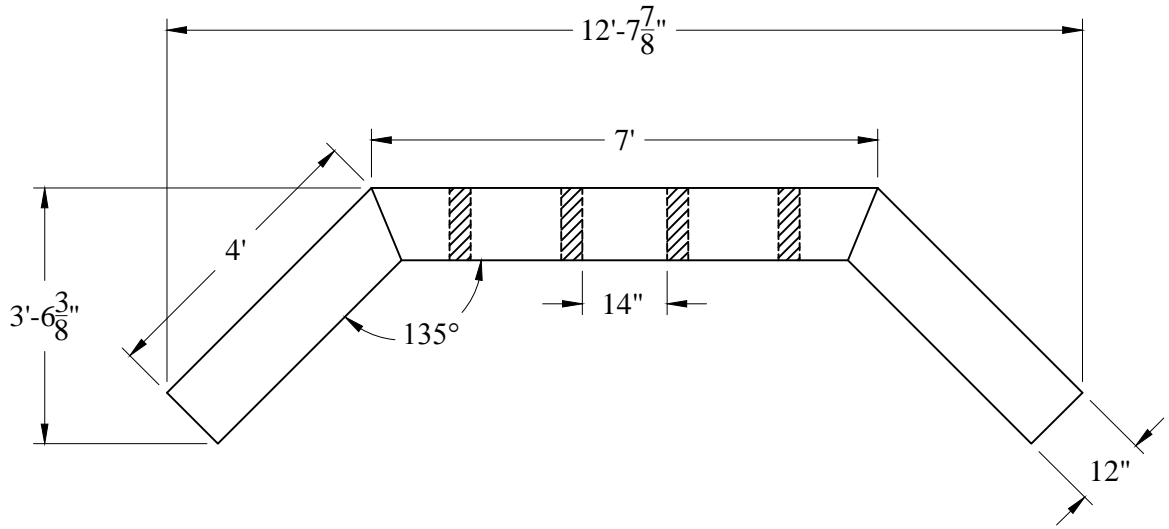

Est Weight: 9,950 Lbs

**General Notes**

1. Precast Concrete Shall Conform to AASHTO M 199. Concrete Shall be Class AAA (f 'c = 5000 psi)
2. Reinforcing Steel Shall Conform to AASHTO M 31, ASTM A-615 Grade 60 Black Deformed Bars

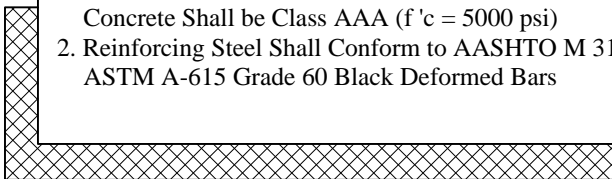

Not to Scale

Phoenix  
Precast  
Products

Dual 15" RCP  
Winged Headwall

P/N: HWW-D15

77 Regional Drive

Concord, NH 03301

Phoenix Precast Products

Phoenix Precast Products